



Model 10A Thermal Gas Mass Flowmeter

- Measures gas flow rate in SCFM, NM³/hr, Lbs/hr, Kg/hr, & many more
- Wide measurement range; 100 to 1 turndown typical
- Insertion and in-line models
- In-line model has built-in flow conditioners
- Advanced Power Pro™ Sensor
- All welded sensor construction
- Microprocessor based, field rangeable
- On board display and configuration panel
- FM and CSA approved
- CE approved
- NIST traceable calibration
- Low-end sensitivity for leak detection
- Negligible pressure drop
- No moving parts design



The Fox Model 10A Thermal Mass Flowmeter is the instrument of choice for reliable and accurate gas mass flow measurement. The instrument measures gas in standard units without the need for temperature and pressure compensation. It provides a 4-20 mA output proportional to mass flow rate in your choice of engineering units (SCFM, NM³/hr, SFPM, Lbs/hr, Kg/hr, etc.). The standard on-board display and configuration panel provides a bright LED read-out of flow rate and total. Wetted parts are 316 stainless steel standard; Hastelloy C276 optional.

All Fox Model 10A Flowmeters are equipped with the revolutionary Power Pro™ thermal mass flow sensor. The Power Pro sensor was designed to operate at a higher power level than competitive models. The elevated power level significantly increases its sensitivity to flow. This results in improved accuracy, measurement range, repeatability and response time.

The Model 10A is available in insertion and in-line configurations. The insertion meter has a rugged 1/2-inch probe in lengths for pipes as small as 1 1/2 inch (40mm), and up to large ducts. The in-line model is available in 1/4 inch to 6 inches and delivered with built-in flow conditioners that eliminate the need for long, straight pipe runs. The meter can be ordered with flanged, NPT, or weld-prep end connections. The Model 10A is FM and CSA approved for hazardous area locations. The very reliable, very accurate Fox Model 10A Thermal Mass Flowmeter is the right choice for your gas flow applications.

Common Gases: Air, ammonia, biogas, butane, chlorine gas, compressed air, carbon monoxide, carbon dioxide, digester gas, ethane, ethylene, flare gas, fuel gas, helium, hydrogen, methane, natural gas, nitrogen, oxygen, propane, vent gas and many more.

Fox has certified cleaning and bagging procedures for flowmeters to be used in oxygen applications.

SPECIFICATIONS

Performance Specs

Accuracy:

± 1.0% of reading + 0.2% of full scale*

* Point velocity for insertion flowmeters. Fox recommends a minimum of 15 diameters of straight pipe upstream of the flowmeter and 10 diameters downstream for insertion flowmeters. Fox recommends a minimum of 8 diameters of straight pipe upstream of the flowmeter and 4 diameters downstream for inline flowmeters.

Calibration:

NIST traceable

Repeatability:

± 0.2% of full scale

Response Time:

0.9 seconds (One time constant)

Operating Specs

Units of Measurement:

SCFM, SCFH, NM³/hr, Kg/hr, Lbs/hr, Lbs/min, NLPM, SFPM

Flow Rates:

Insertion Flowmeters

0 to 32,000 SFPM (0-163 NMPS). To determine if an Insertion Flowmeter will operate properly, divide the maximum flow rate by the pipe area. Here are flow rates for common pipe sizes:

Pipe Size	SCFM	NM ³ /hr
1-1/2" (40mm)	0-450	0-760
2" (50mm)	0-750	0-1280
3" (80mm)	0-1600	0-2720
4" (100mm)	0-2880	0-4893
6" (150mm)	0-6400	0-10870
8" (200mm)	0-11100	0-18860
10" (250mm)	0-18200	0-30920
12" (300mm)	0-24900	0-42300

Use the equation above for larger pipe sizes.

In-Line Flowmeter

Pipe Size	SCFM	NM ³ /hr
0.25-inch	0-16	0-27
0.5-inch	0-48	0-82
0.75-inch	0-120	0-204
1-inch	0-192	0-326
1.25-inch	0-332	0-564
1.5-inch	0-450	0-760
2-inch	0-750	0-1280
2.5-inch	0-1090	0-1855
3-inch	0-1600	0-2720
4-inch	0-2880	0-4893
6-inch	0-6400	0-10870

Note: Standard conditions for air at 70°F and one atmosphere. Consult factory for other gases and for flow ranges above those listed above.

Gas Pressure (maximum):

Insertion Flowmeter:

500 psig (34.5 barg)

In-Line (1/4" through 6"):

NPT 500 psig (34.5 barg)

150# flange 230 psig (16 barg)

Check with factory for higher pressure options

Note: Pressure ratings stated for temperature of 100°F (38°C).

Temperature:

Sensor -40 to 250°F (-40 to 121°C)

HS Sensor 32 to 400°F (0 to 204°C)

Enclosure -40 to 131°F (-40 to 55°C)

Input Power:

Explosion proof enclosure

24 VDC, ± 10%, 0.75 amp max

Remote NEMA 4X enclosure

85-250 VAC, 50/60 Hz, 25 watts max

Note: NEMA 4x enclosure is not FM or CSA approved

Output:

4-20 mA, isolated

Alarm relay; dry contact;

50 VAC, 30 VDC, 3 amp

Physical Specs

Sensor Wetted Materials:

316 stainless steel standard, Hastelloy C276 optional

Remote cabling:

2-conductor, 18 AWG twisted, shielded, 500 ft. maximum

Enclosures

Explosion Proof Enclosure:

Cast aluminum; FM and CSA approved for Class I, Division 1, Groups B, C, & D Temperature: T3C (160°C). FM approved Dust Ignition Proof for Class II/III, Division 1, Groups E, F & G; indoor/outdoor NEMA Type 4. CE Approved

Remote NEMA 4X Enclosure:

Fiberglass; Non-explosion proof, not FM or CSA approved

Dimensional

Insertion Flowmeters:

Probe diameter: 1/2"; Installation Coupling

3/4-inch NPT

Equation for selecting Insertion Flowmeter probe length:

Probe length = 1/2 pipe ID (in inches) + 3" + thickness of insulation (if any) + dimension of retractor (if supplied). Round up to the next standard probe length available.

Insertion Flowmeter Probe Lengths (LL) = (See Figures 1 & 5)

4.0(10.2), 6.0(15.2), 9.0(22.9), 12.0(30.5), 15.0(38.1), 18.0(45.7), 24.0(61.0), 30.0(76.2), 36.0(91.4). Contact Fox for longer probes.

Note: Dimensions in parenthesis are centimeters. For certified drawings, consult factory.

Assuming there is no insulation or retractor, Fox recommends the following probe lengths:

Pipe Size	Probe Length
1-1/2" (40mm) to 2" (50mm)	4-inch
2.5" (mm) to 6" (mm)	6-inch
8" (mm) to 12" (mm)	9-inch
14" (mm) to 18" (500mm)	12-inch
Use the equation above for larger pipe sizes	

Inline Flowmeters (Figures 2, 3 & 4)		
Pipe size	L	H
0.25"	5.80 (14.7)	12.5 (31.8)
0.5"	12.0 (30.5)	12.5 (31.8)
0.75"	12.0 (30.5)	12.5 (31.8)
1"	15.0 (38.1)	12.5 (31.8)
1.5"	12.0 (30.5)	12.5 (31.8)
2"	12.0 (30.5)	12.5 (31.8)
2.5"	18.0 (45.7)	12.6 (32.0)
3"	18.0 (45.7)	12.6 (32.0)
4"	18.0 (45.7)	13.1 (33.3)
6"	24.0 (61.0)	14.2 (36.1)

Note: Dimensions in parenthesis are centimeters. For certified drawings, consult factory.

Theory of Operation

Fox Flowmeters use a Constant Temperature Differential (ΔT) technology. The sensor has two elements. The Reference RTD measures the gas temperature. The electronics heat the Heated Element above the gas temperature. It is the job of the electronics to maintain a constant ΔT between the gas temperature and the Heated Element. As mass flow increases, the increased numbers of gas molecules remove more heat from the Heated Element.

The electronics sense this temperature reduction and adds additional power to the heated element in order to maintain a constant ΔT . The amount of power delivered to the Heated Element is proportional to the mass flow rate. The microprocessor then linearizes this signal to deliver a linear output.

Pressure Drop Charts for Inline Flowmeters

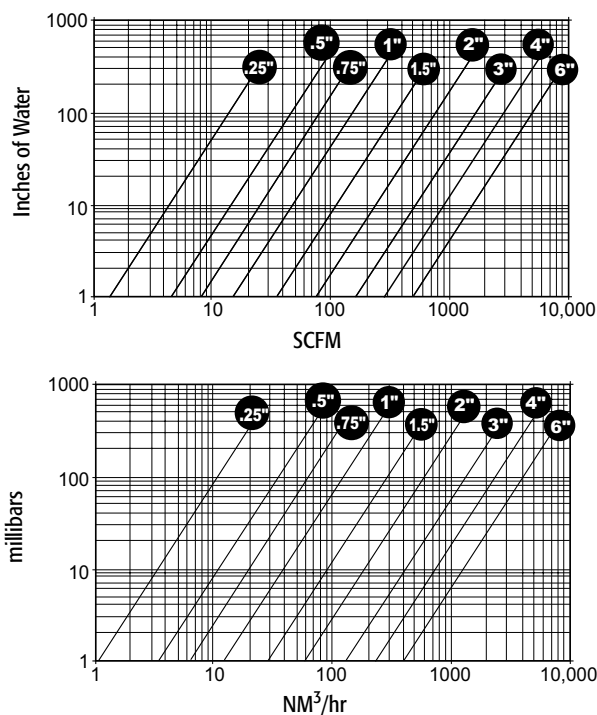

Figure 1: Insertion 4" to 36" (10.2 to 91 cm)

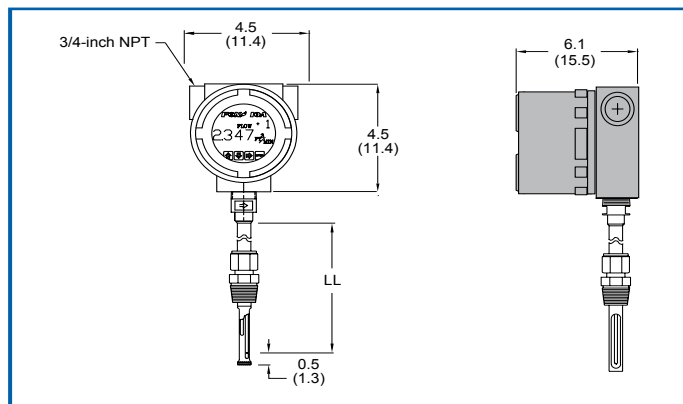
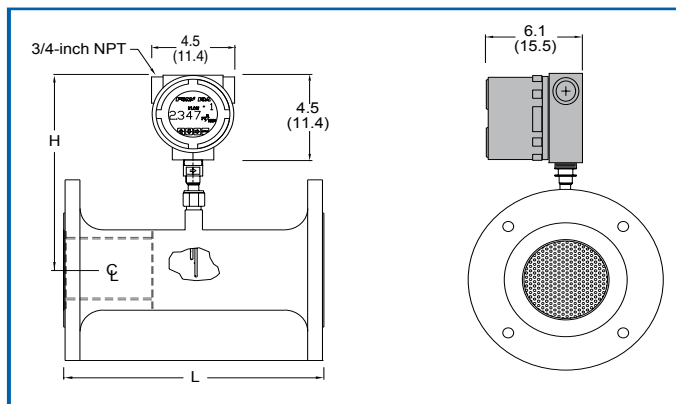

Figure 2: In-Line with 150# Flanges – sizes 0.5" to 6"



DIAGRAMS

Figure 3: Inline with NPT Fittings – sizes 0.25" to 6"

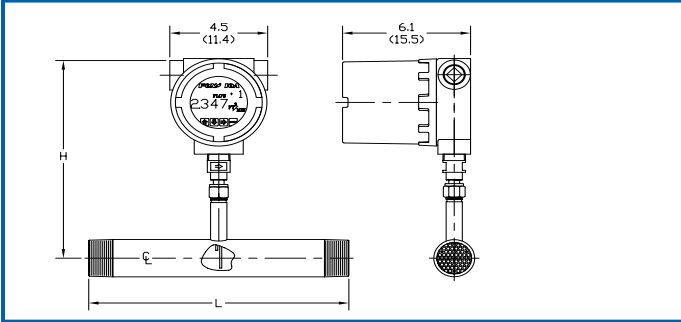

Figure 4: Inline with NPT Fittings & remote NEMA 4X Enclosure

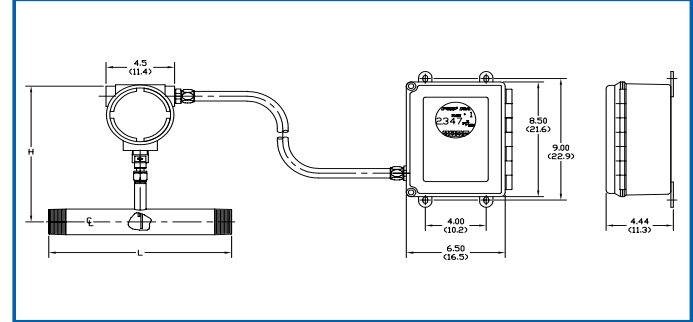

Figure 5: Insertion with remote explosion-proof enclosure

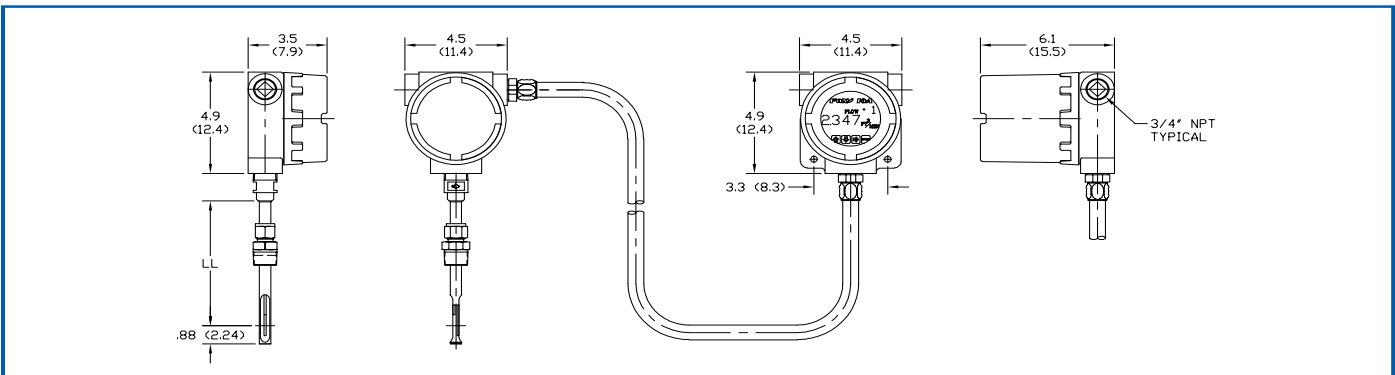

Figure 6: Packing Gland assembly - 125 psig (8.6 barg) maximum

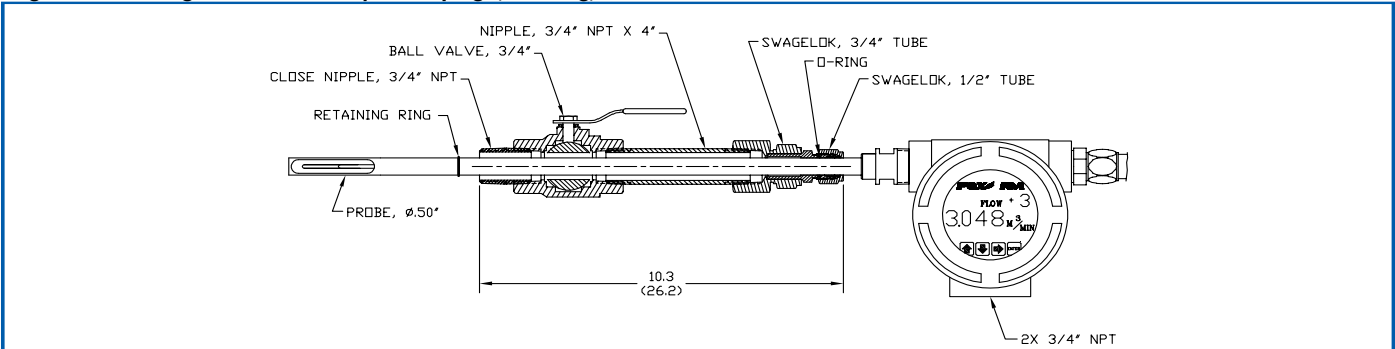
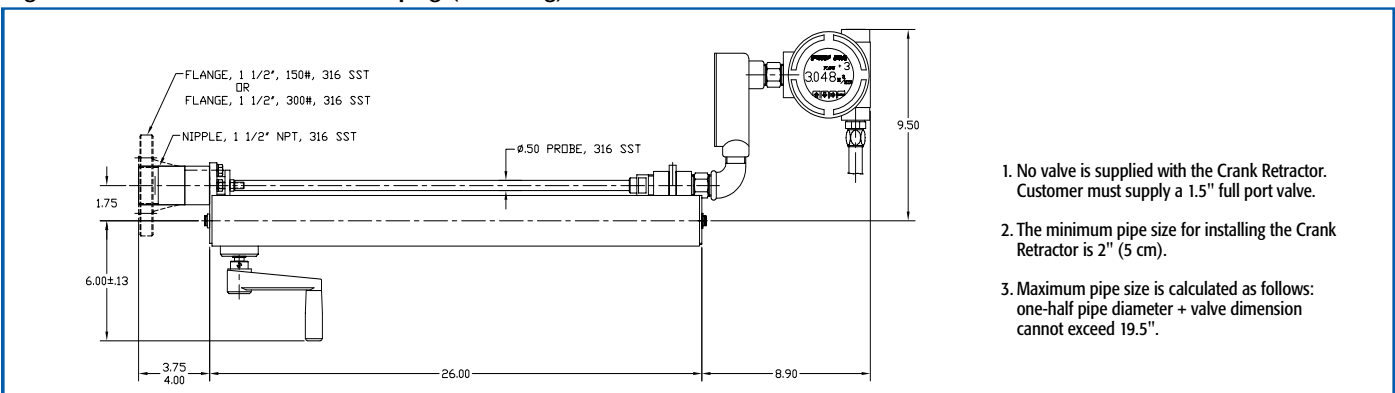

Figure 7: Crank Retractor - NPT 600 psig (41.4 barg); ANSI 150 & ANSI 300



FOX THERMAL INSTRUMENTS, INC.
399 RESERVATION ROAD X MARINA, CA 93933 X USA
PHONE: 831-384-4300 X FAX: 831-384-4312
E-MAIL: sales@foxthermalinstruments.com
www.foxthermalinstruments.com